



ATHLETA
POWER TO THE SHE

JONNY HOOLKO
ROXANNA BAILEY

PHASE 1: EXHIBITION OVERVIEW

PAGE 2	EXHIBITION BRIEF
PAGE 3	PARTI DIAGRAMS
PAGE 5	MASSING DIAGRAMS
PAGE 6	DEVELOPMENTAL SKETCHES
PAGE 7	PRODUCT OVERVIEW

EXHIBITION BRIEF

COMPANY NAME

ATHLETA

ACTIVITY

CLOTHING RETAILER

PRODUCT CATEGORY

WOMEN'S ACTIVEWEAR

WEBSITE

ATHLETA.GAP.COM

ANNUAL EXPO ATTENDANCE

ATHLETA FIRST ATTENDED NEW YORK FASHION WEEK SEPTEMBER 2014, THEIR LARGEST EXPO EVENT TO DATE.

BUSINESS OBJECTIVES

SHOWCASE 3 NEW SEASONS OF CLOTHING (FALL, WINTER SPRING) AND EMPOWER FEMALE ATHLETES.

TARGET AUDIENCE

CIP GUESTS: CUSTOMERS, FEMALE ATHLETES OF ALL LEVELS
VIP GUESTS: ASSOCIATED PRESS, SPECIFICALLY TOP BLOGGERS

BOOTH SIZE/FLOOR PLAN

10,268 SQ FT
SINGLE LEVEL FLOORPLAN

BOOTH TYPE

BUILD AND BURN
ISLAND BOOTH

PRODUCT DISPLAY

MANEQUINNS IN ACTIVE POSES WILL SHOWCASE 8 OUTFITS FROM ATOP THE LAYERED STRUCTURES. ADDITIONAL MANEQUNNS WILL DISPLAY CLOTHING ALONG THE PERIMETER OF THE EXHIBIT, VISIBLE FROM THE OUTSIDE.

CIP/VIP SPACES

A VIP SPACE ON TOP STRUCTURE 3 WILL ALLOW VIP GUESTS TO WATCH THE STAGE PERFORMANCE FROM ABOVE AND BLOG ABOUT THEIR EXPERIENCES. A MULTI-USE EXERCISE STUDIO IN STRUCTURE 2 WILL BE AVAILABLE TO CIP GUESTS.

LIGHTING

THE EXHIBIT WILL BE LIT BY OVERHEAD "HALO" LIGHTS AND RECESSED LIGHTING UNDER LAYERS OF THE ARCHITECTURAL STRUCTURES. ADDITIONALLY, THE CIP STUDIO WILL FEATURE PRESSURE-SENSITIVE LIT FLOORING, AND THE ROCK WALL WILL FEATURE PRESSURE-SENSITIVE ROCK HOLDS.

LOCK UP/STORAGE

PRODUCT DISPLAYS WILL BE STORED INSIDE STRUCTURE 1.

INFORMATION DESK

AN INFORMATION DESK AT THE NORTHWEST ENTRANCE OF THE EXHIBIT AILL ORIENT AND INFORM VISITORS.

LOGO/GRAPHICAL ELEMENTS

THE ATHLETA LOGO WILL BE DISPLAYED REPEATEDLY ALONG THE PERIMETER OF THE EXHIBIT. A MURAL SPANING THE INTERIOR OF STRUCTURES 1 AND 2 WILL ILLUSTRATE THE INCREASING PREVALENCE OF WOMEN IN SPORTS.

SCREEN AREA

IN PLACE OF SCREENS, THERE WILL BE LIVE ATHLETIC PERFORMANCES ON THE CENTRAL STAGE.

PARTI DIAGRAMS

IN THIS EXHIBIT, WE WANTED TO SHOW THE MODERN FEMALE ATHLETE IN MOTION. THIS PROCESS BEGAN WITH AN EXPLORATION OF REPRESENTING MOTION THROUGH FORM. WE WANTED TO SHOWCASE ATHLETA'S VISION OF VERSATILE CLOTHING FOR BOTH FASHION AND FITNESS IN OUR DESIGN. WE WERE INSPIRED BY THE TRACK AND THE BODY OF THE FEMALE ATHLETE.



PARTI DIAGRAMS

INSPIRATION

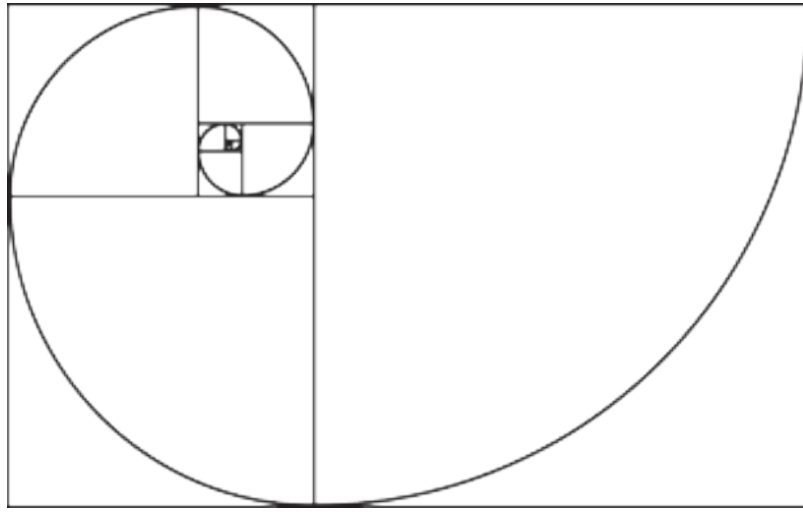

ORIGINAL FLOOR PLAN

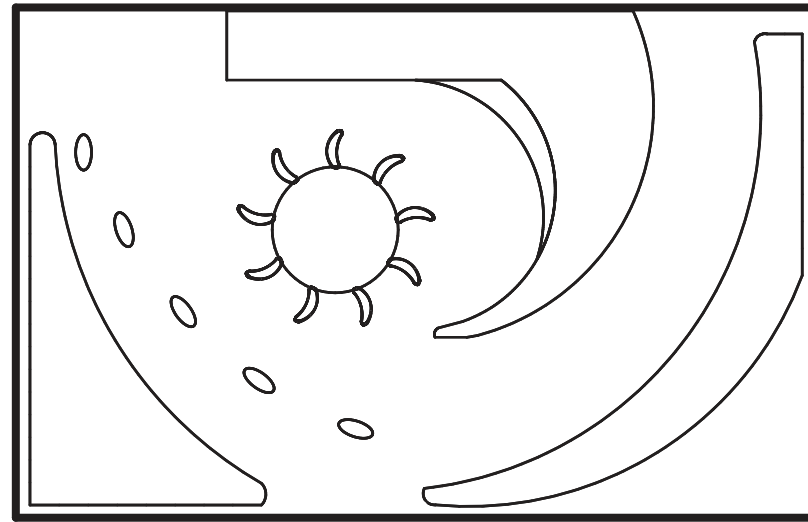

THE BOTTOM DIAGRAM SHOWS AN ACCELERATION OF MOVEMENT, EMPOWERMENT, AND COLOR INTENSITY. TO REPRESENT THIS ACCELERATION, WE CHOSE THE FIBONACCI SPIRAL AS THE BASIS FOR OUR FLOOR PLAN.

Walk

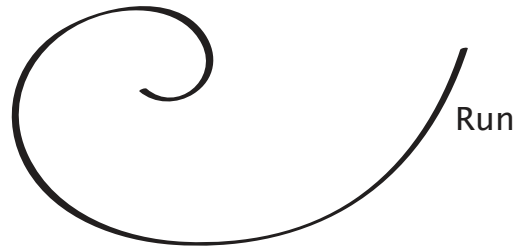

Inequality

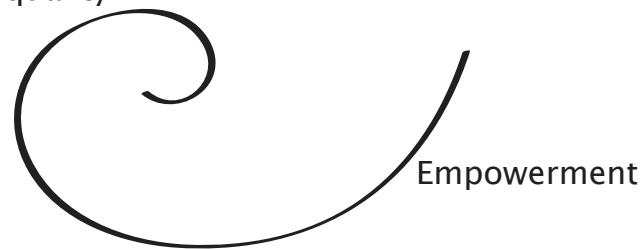

Achromatic

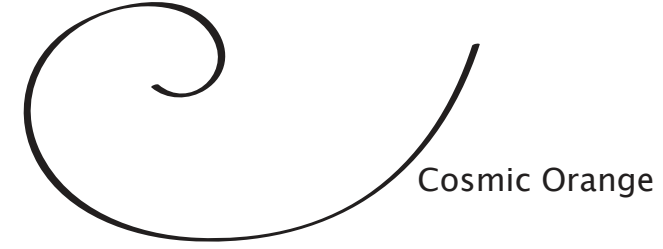

MASSING DIAGRAMS

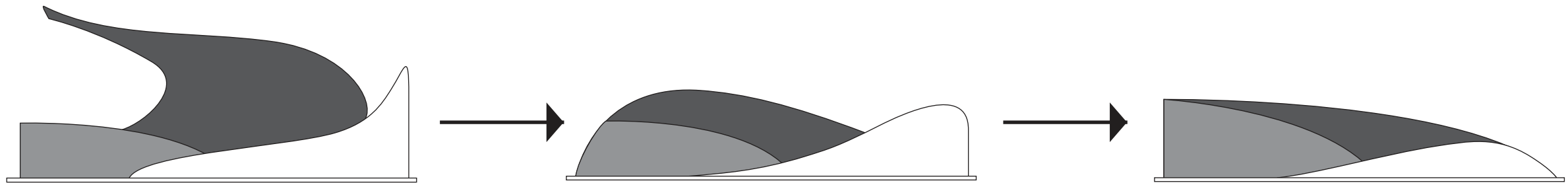

ONCE WE DECIDED ON THREE MAIN STRUCTURES, WE EXPERIMENTED WITH THE HEIGHTS OF THE STRUCTURES. THE BOTTOM IMAGE SHOWS A FIGURE-GROUND SECTION OF OUR FINAL DESIGN TO ILLUSTRATE THE VARYING HEIGHTS OF THE STRUCTURES RELATIVE TO OUR INITIAL IDEA.



DEVELOPMENTAL SKETCHES

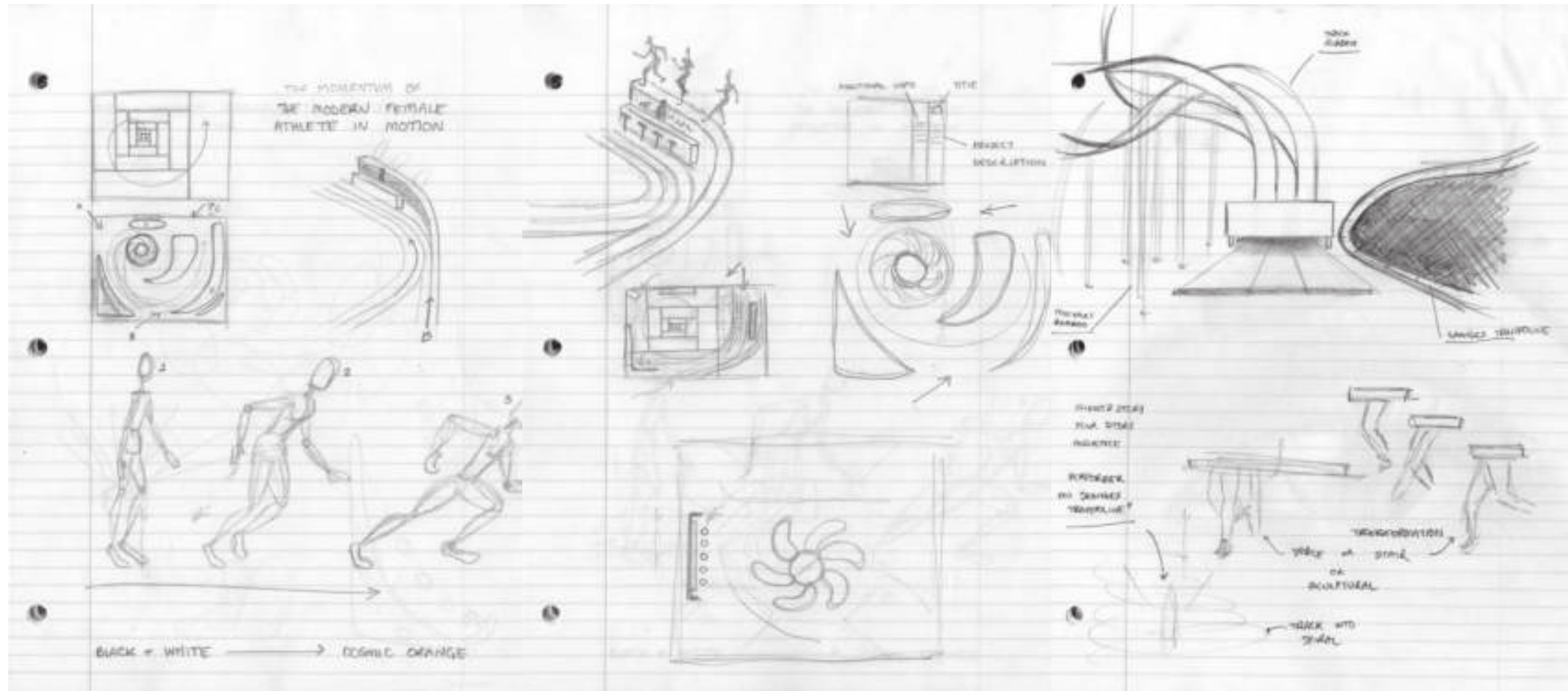

OUR CONCEPTUAL SKETCHES SHOW A TRANSFORMATION OF THE TRACK AND THE FEMALE BODY.

PRODUCT OVERVIEW



FUSE BRA



STING STUNNER BRA



UP-TEMPO STRIPE SEAMLESS BRA



METALLIC DOWN JACKET



MARIBEL SKI JACKET



ACACIA SWEATER



CASHMERE SURREY SWEATER



CHILL TEXTURED SWEATER JACKET



UPSIDE VEST

PRODUCT OVERVIEW



CHOLEAH BOOT BY ADIDAS



GAETANA BOOT BY PAJAR



JAZZ ORIGINAL SHOE BY SAUCONY



MARIBEL SKI PANT



EMBODIMENT TIGHTS



WESTCHESTER CHATURANGA TIGHT

PHASE 2: SPATIAL PLANNING

PAGE 11	FLOOR PLAN
PAGE 13	SECTIONS
PAGE 15	ELEVATIONS
PAGE 17	CIRCULATION
PAGE 18	MATERIALS AND FURNITURE
PAGE 19	LIGHTING PLAN

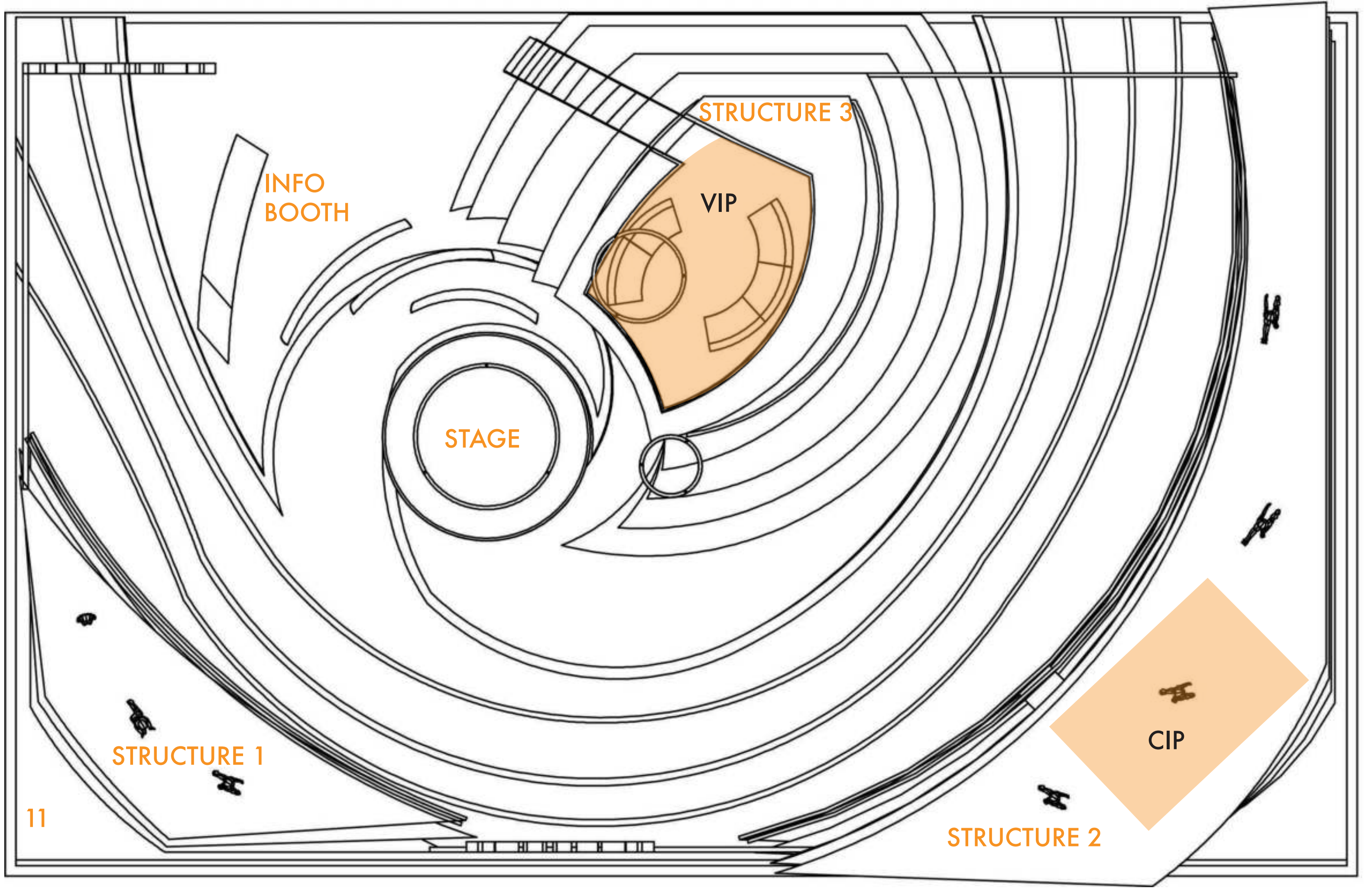

INFO
BOOTH

STRUCTURE 3

VIP

STAGE

CIP

STRUCTURE 1

STRUCTURE 2

11

FLOOR PLAN

THE THREE STRUCTURES FORM A SPIRAL VOID FOR VISITORS TO WALK AROUND. THE CIRCULAR STAGE IN THE CENTER ACTS AS THE LIFE FORCE OF THE EXHIBIT, WHERE FEMALE ATHLETES PERFORM A VARIETY OF ATHLETIC SHOWS. GUESTS CAN WATCH PERFORMANCES, GAIN MORE INFORMATION ON PRODUCTS FROM THE INFO BOOTH, EXPLORE THE MURAL WALL OF FEMALE ATHLETES THROUGHOUT HISTORY, CLIMB ON THE ROCK WALL, AND VIEW ATHLETA CLOTHING ON ACTIVELY-POSED MANNEQUINS ON TOP OF STRUCTURES 1 AND 2. VIP GUESTS ASCEND THE STAIRCASE TO THE TOP OF STRUCTURE 3, WHERE THEY CAN WATCH THE PERFORMANCES AND BLOG ABOUT THEIR EXPERIENCES. CIP GUESTS CAN ENTER THE STUDIO INSIDE STRUCTURE 2, WHERE YOGA AND GROUP EXERCISE CLASSES WILL BE HELD REGULARLY. THE HEADERS AT THE NORTHWEST AND SOUTH ENTRANCES INTRODUCE GUESTS TO THE SPACE.



SECTIONS

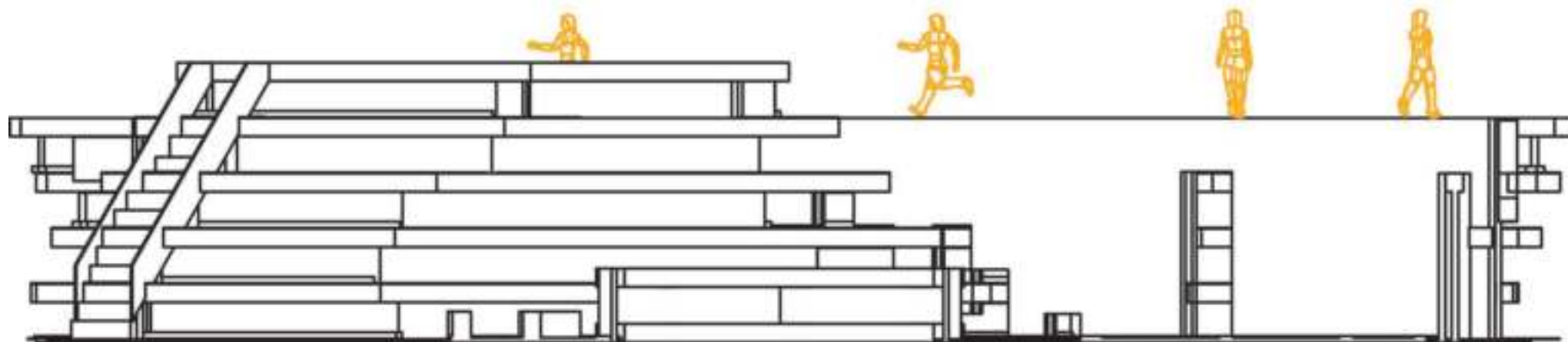
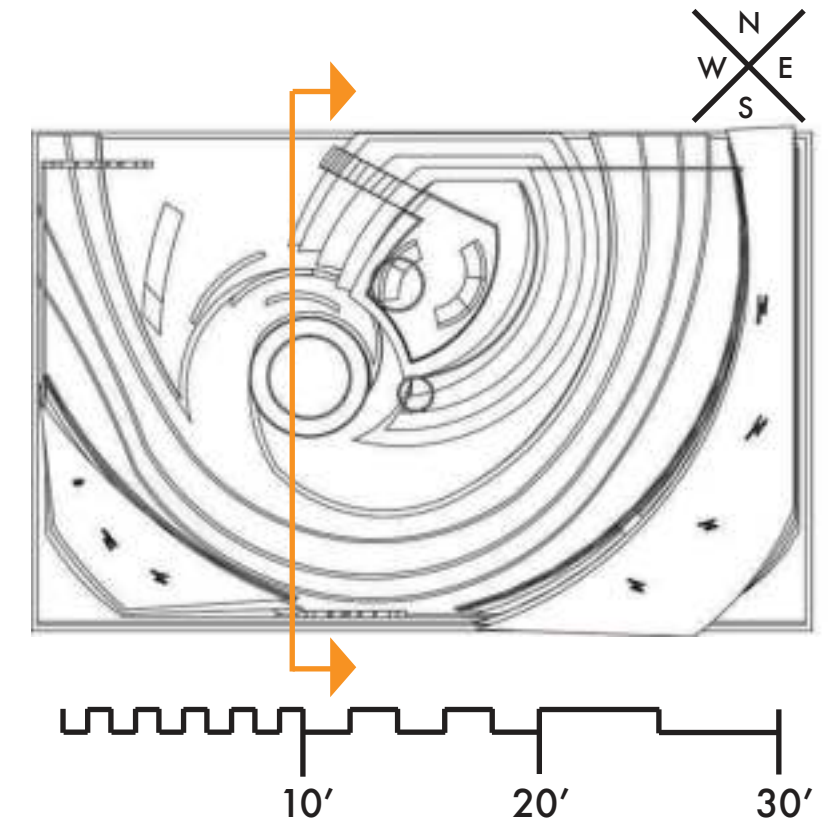
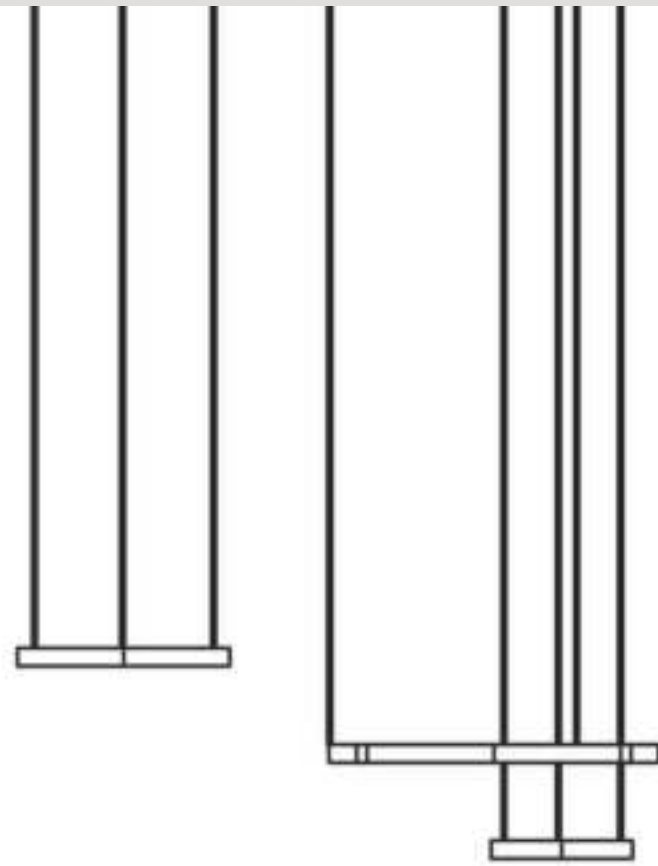

SECTIONS

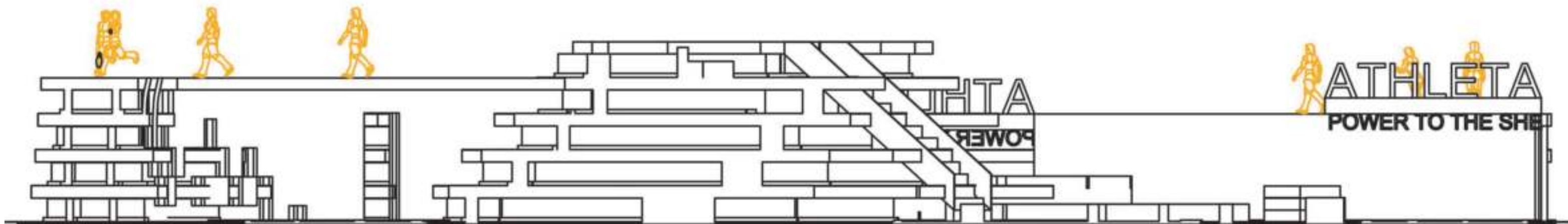
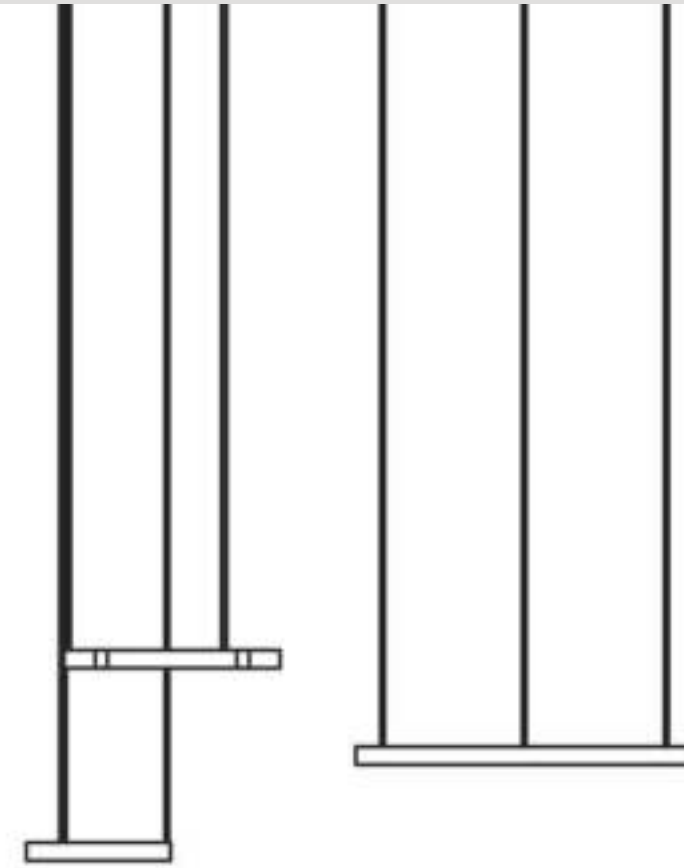
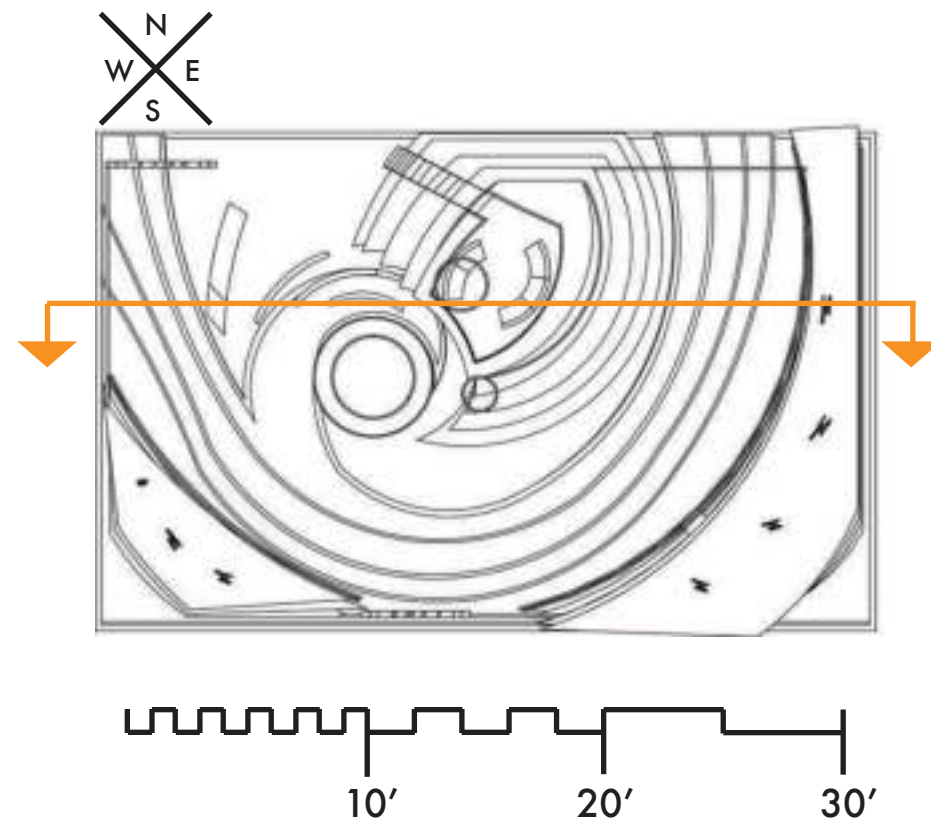

ELEVATIONS



WEST ELEVATION

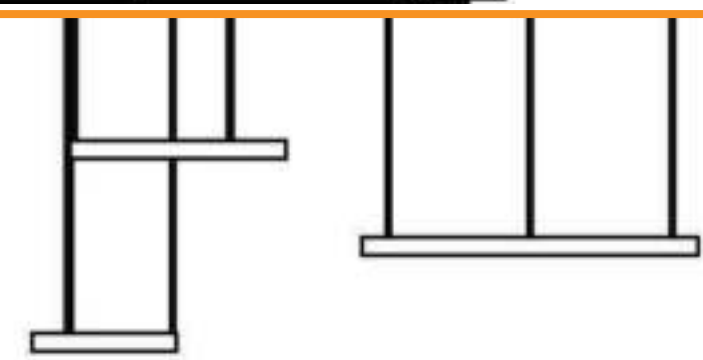

NORTH ELEVATION

15

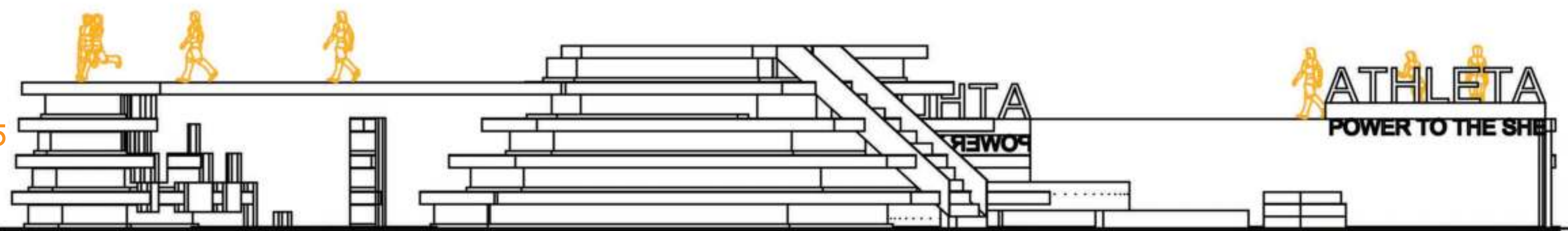

ELEVATIONS

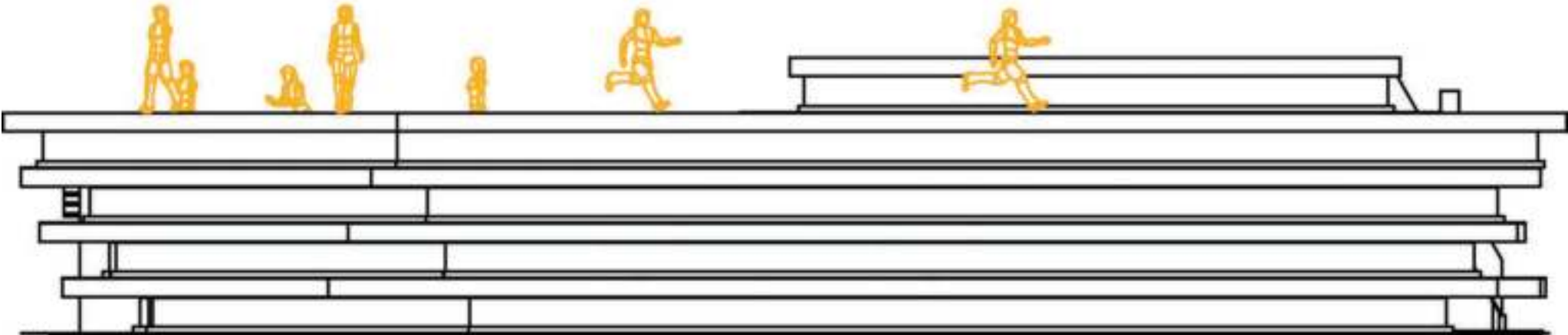
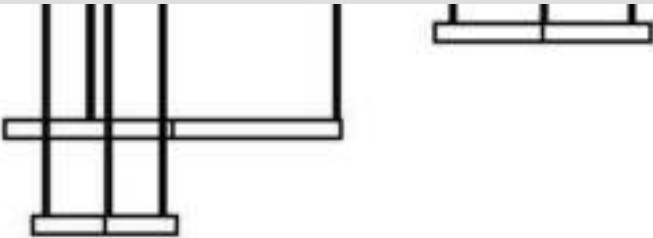

EAST ELEVATION

SOUTH ELEVATION

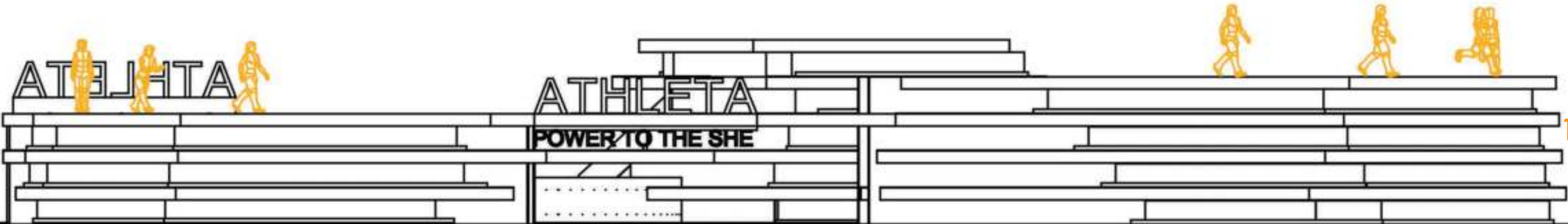
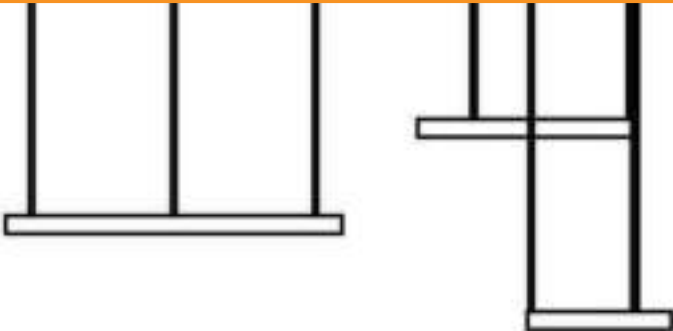

CIRCULATION

THE INTENDED ROUTE OF CIRCULATION IS SHOWN IN ORANGE. GUESTS WILL PRIMARILY ENTER FROM THE NORTHWEST CORNER; HOWEVER, SOME CIRCULATION IS EXPECTED FROM THE SOUTH BORDER. THE STAGE AND THE MANNEQUINS CAN BE SEEN FROM BOTH ENTRANCES. GUESTS WILL SEE AN INCREASE IN THE COLOR ORANGE AS THEY MOVE COUNTERCLOCKWISE THROUGHOUT THE SPACE.

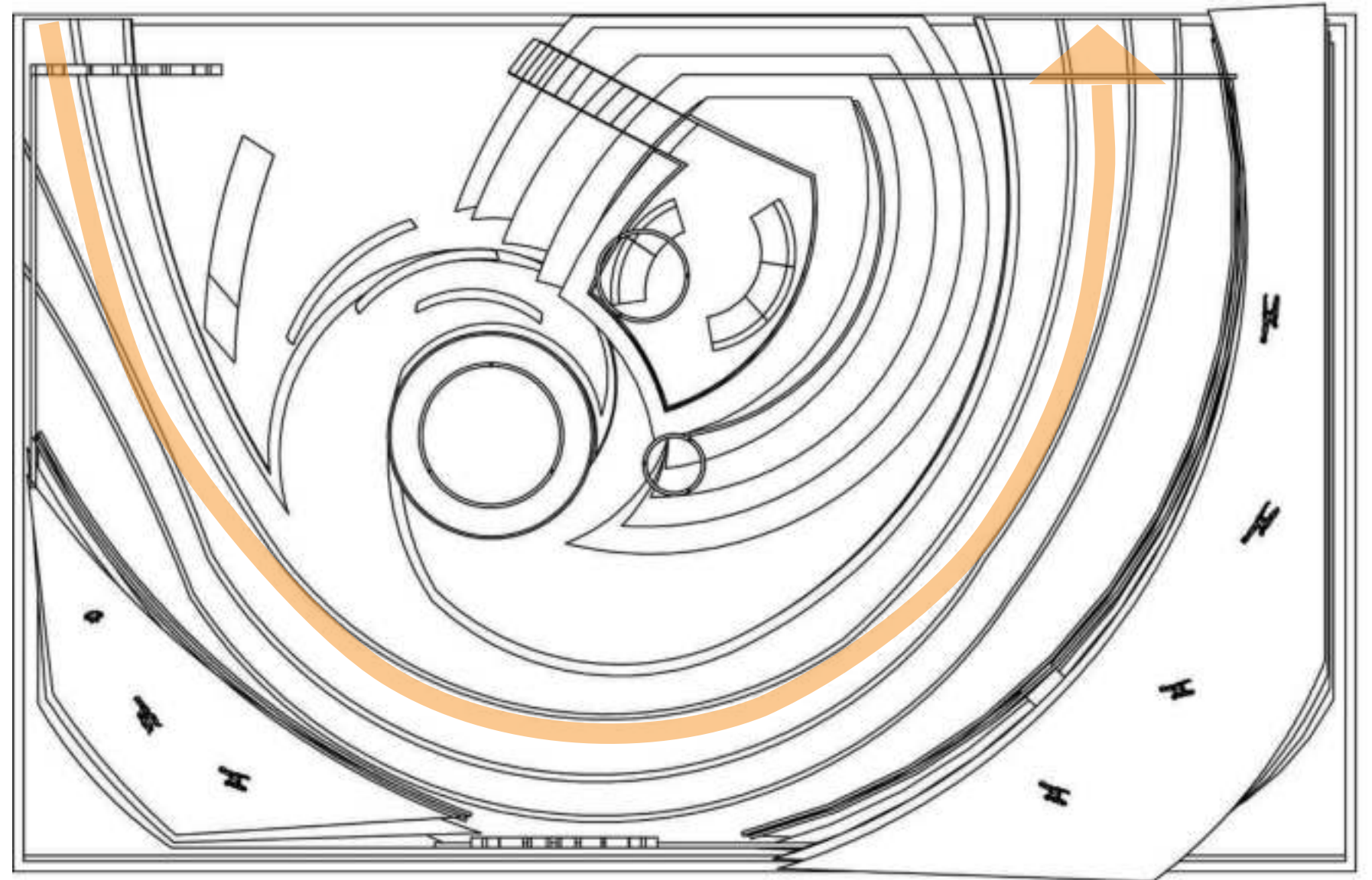

MATERIALS AND FURNITURE

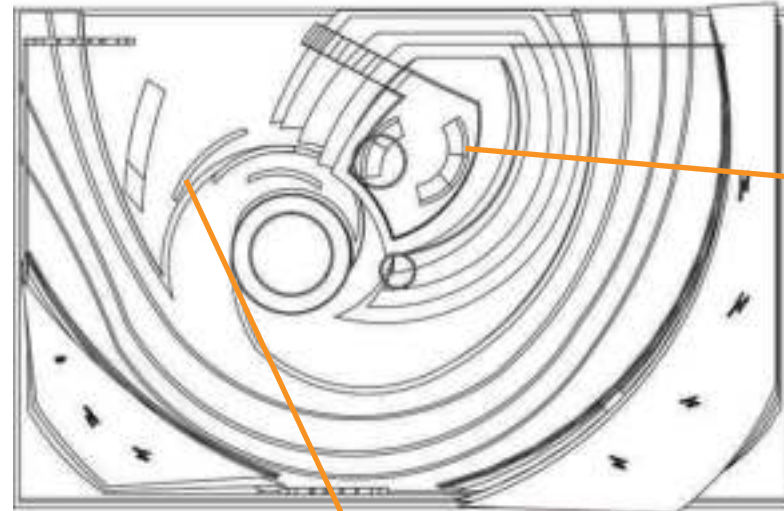

COMFORTABLE, MODULAR COUCH SEATING WILL BE SITUATED IN THE VIP AREA ATOP STRUCTURE 3 TO ENCOURAGE GUESTS TO STAY AND TALK.









THE MOST PROMINENT CONSTRUCTION MATERIALS WILL BE ACRYLIC, GLASS, AND POLYURETHANE TRACK MATERIAL. THE MATERIALS WILL BE MOSTLY ACHROMATIC WITH POPS OF "COSMIC ORANGE."

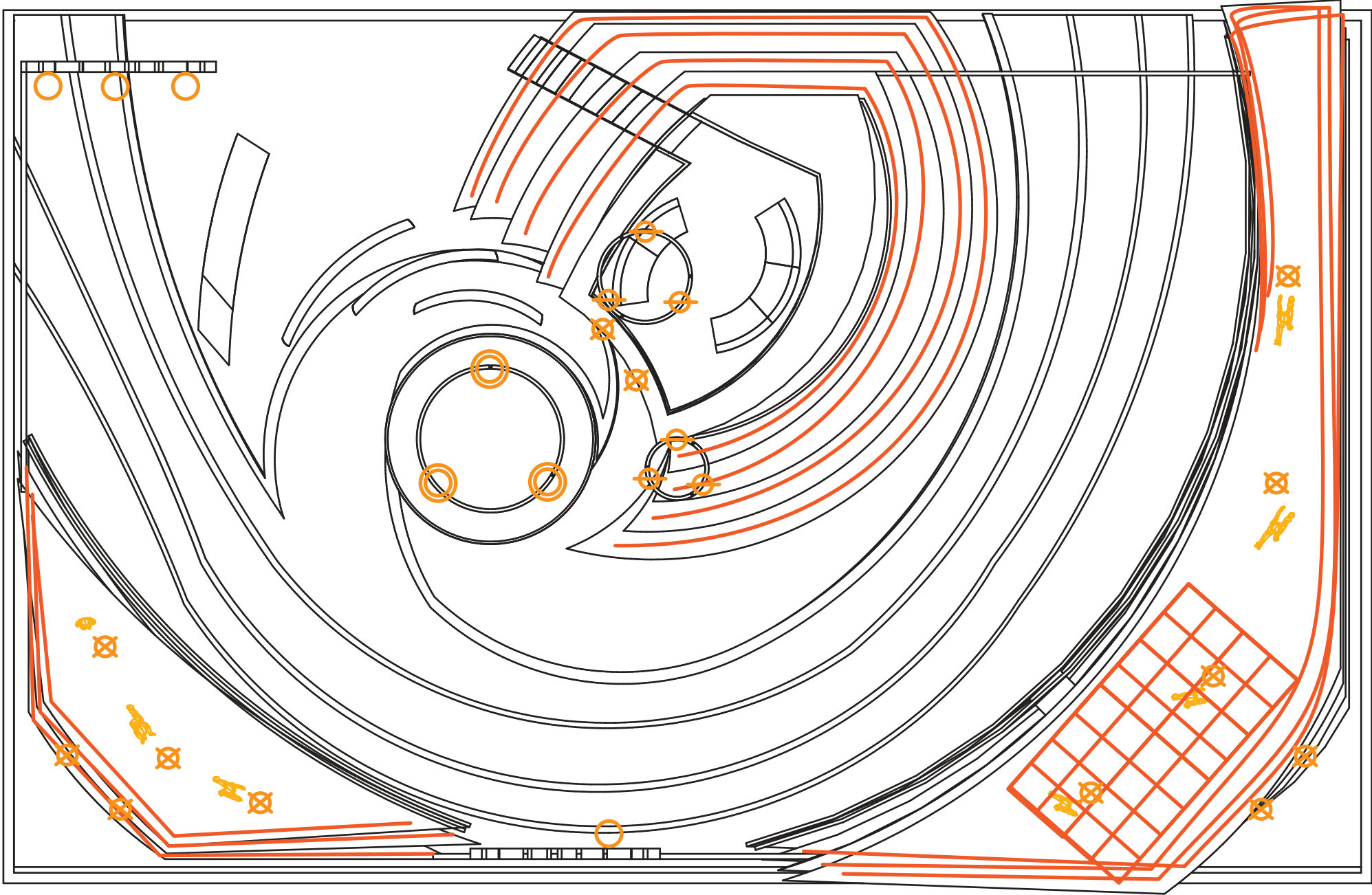

CURVED BENCHES WILL FRAME THE STAGE SO GUESTS CAN WATCH THE ATHLETIC PERFORMANCES.

LIGHTING PLAN



Icon	#	Manufacturer	Product	Watts	Lumens	Qty	CRI	CCT
	1	Juno	6" Eyeball Trim Downlight	10.5	600	6	85	4100K
	2	Cree	LR6	11	1000	4	90	4000K
	3	Soraa	Par30 Shortneck Narrow Flood	18.5	1050	3	95	4000K
	4	Soraa	MR16	9	490	13	95	3000K
	#	Manufacturer	Product	Watts	Lumens	Qty	CRI	CCT
	1	Sensacell	W3016-16-RGB (1 ft/sq)	5.5	n/a	240	n/a	n/a
	2	Moda Light	Super Neon X Flat (30ft)	4.7	127/ft	48	88	4000

PHASE 3: EXHIBITION STAGING

PAGE 23	INTERIOR RENDERINGS
PAGE 26	MODEL PHOTOGRAPHS
PAGE 30	INTERACTIVE DESIGN

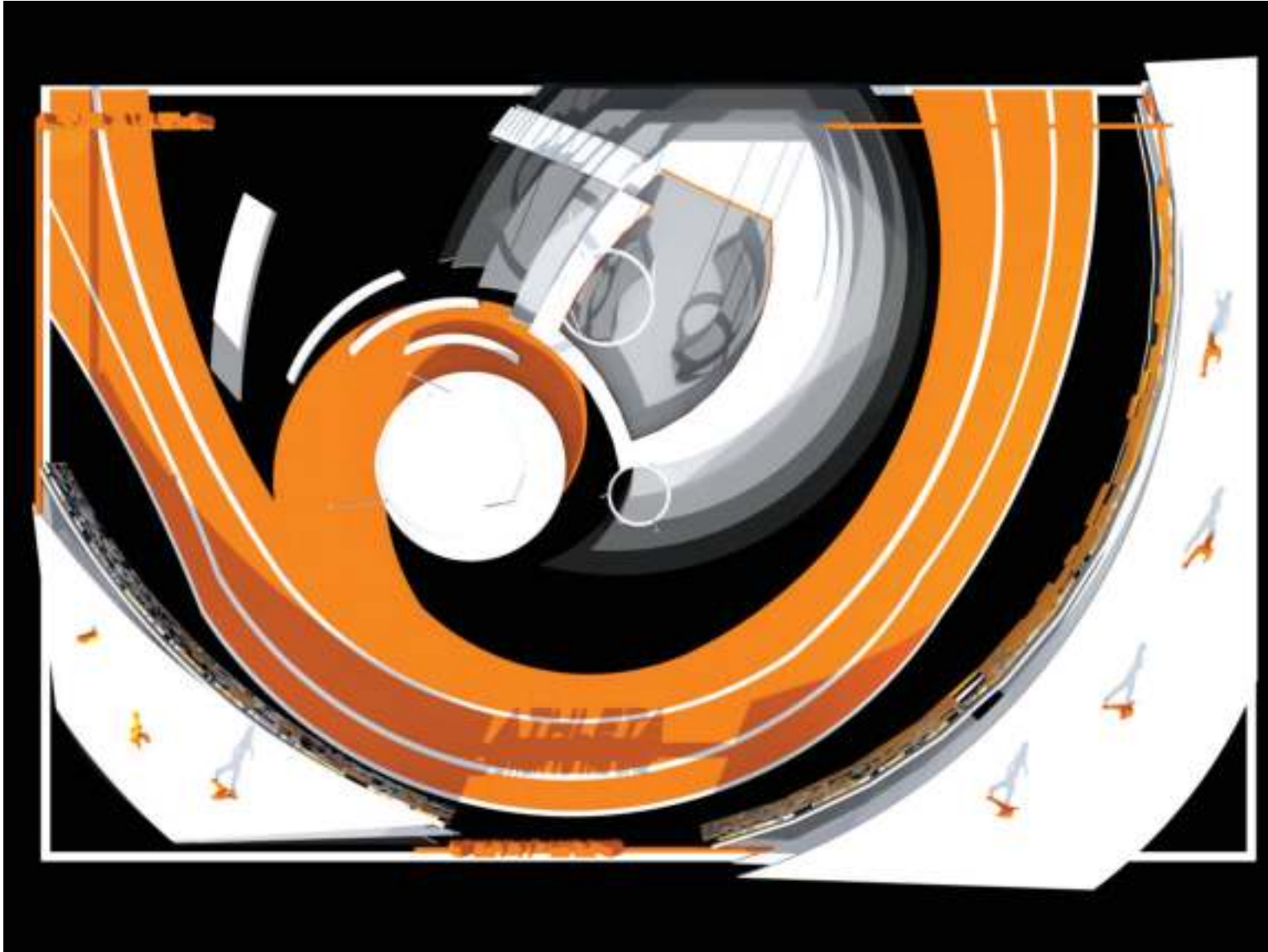

PLAN VIEW RENDERING



ELEVATED VIEW FROM
NORTHWEST CORNER

INTERIOR RENDERINGS



VIEW FROM THE SOUTH SIDE



VIEW OF VIP AREA AND
STAGE

INTERIOR RENDERINGS



ELEVATED VIEW FROM THE
NORTH SIDE

MODEL PHOTOGRAPHS



PLAN VIEW PHOTOGRAPH OF MODEL



VIEW FROM THE NORTHWEST CORNER

MODEL PHOTOGRAPHS



INTERIOR VIEW OF TRACK AND MURAL

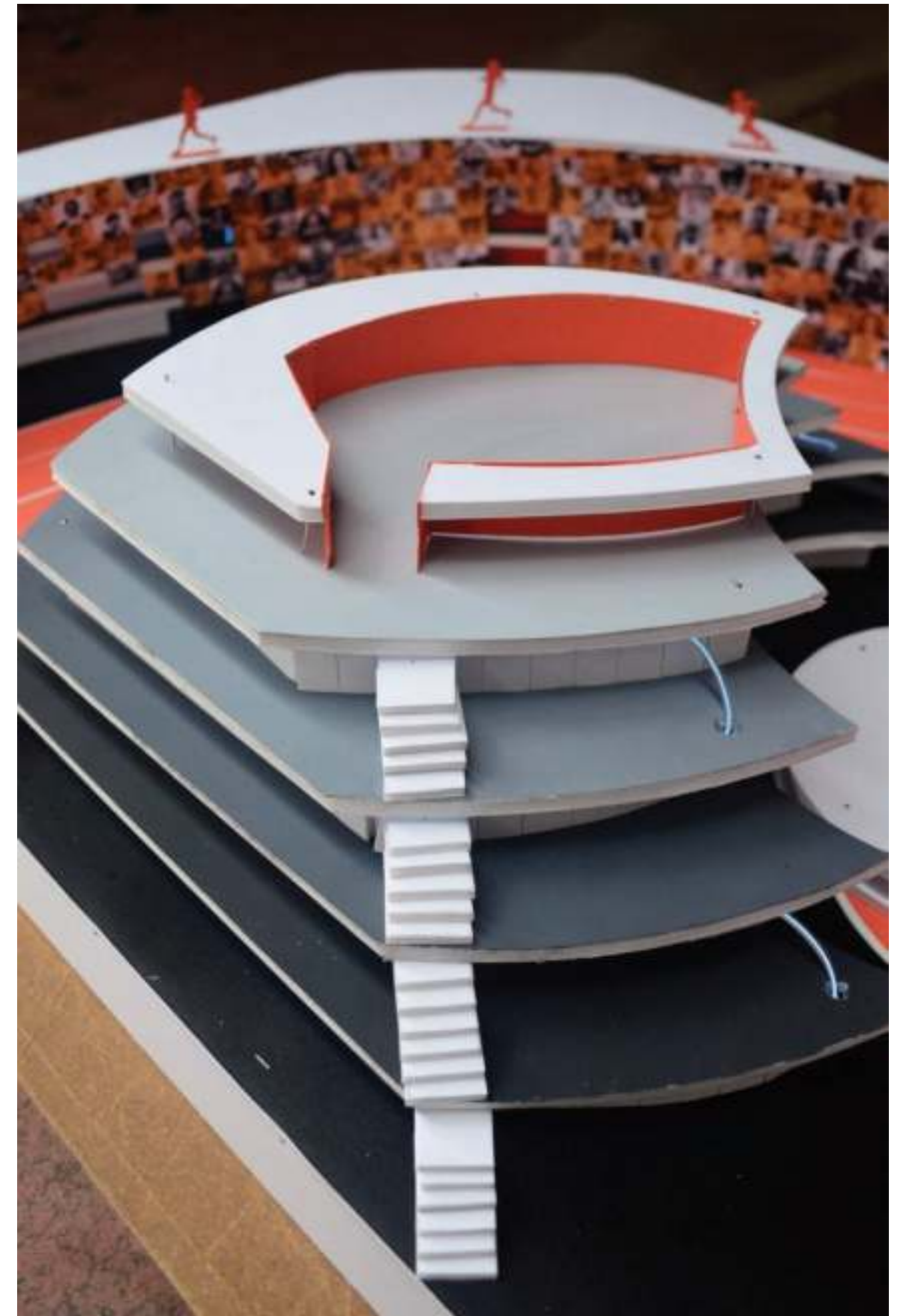

VIEW OF VIP SECTION

MODEL PHOTOGRAPHS

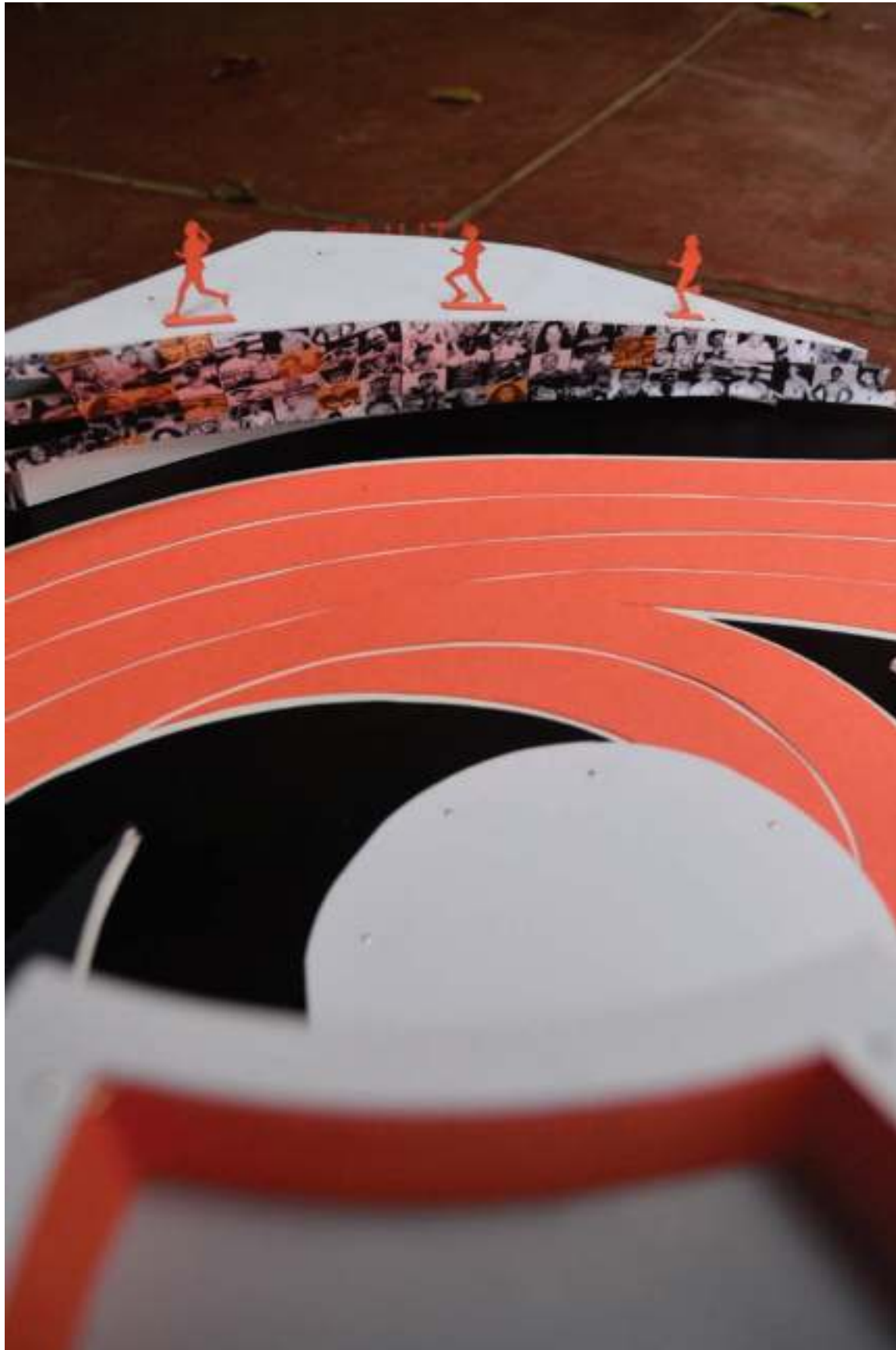

VIEW OF STAGE FROM VIP SECTION



ELEVATED VIEW OF STAGE AND STRUCTURE 3

MODEL PHOTOGRAPHS



LIT VIEW OF EXTERIOR FROM SOUTHEAST CORNER



LIT VIEW OF STRUCTURE 3 FROM NORTH SIDE

INTERACTIVE DESIGN



THE ROCK WALL ON STRUCTURE 1 WILL INVITE GUESTS TO PHYSICALLY INTERACT WITH THE SPACE. SOME OF THE ROCK HOLDS WILL BE MADE OF OPAQUE ACRYLIC AND OTHERS WILL BE TRANSPARENT WITH PRESSURE-SENSITIVE LED LIGHTS INSTALLED. WHEN A GUEST GRABS A HOLD OF ONE OF THE TRANSPARENT HOLDS, IT WILL ILLUMINATE. IN KEEPING WITH ATHLETA'S BRAND OBJECTIVES, THIS INSTALLATION WILL ENCOURAGE MOVEMENT AND EXERCISE.

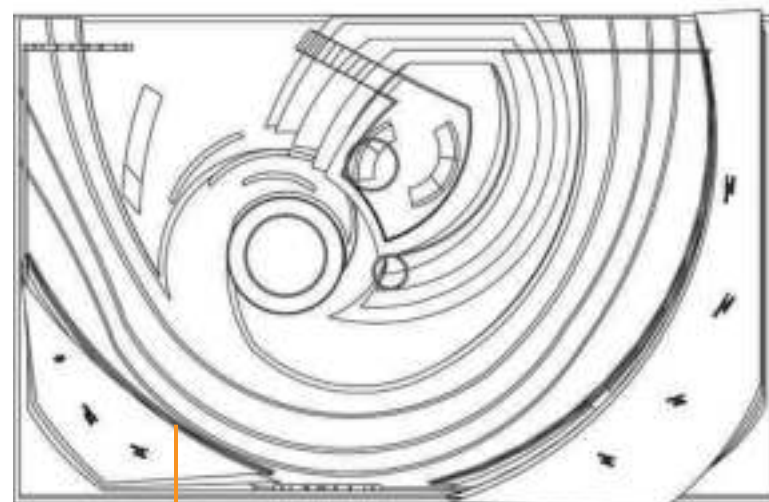
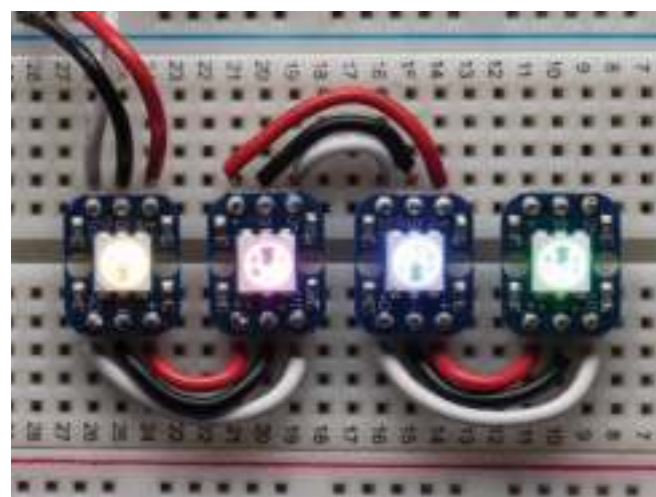

ROCK WALL

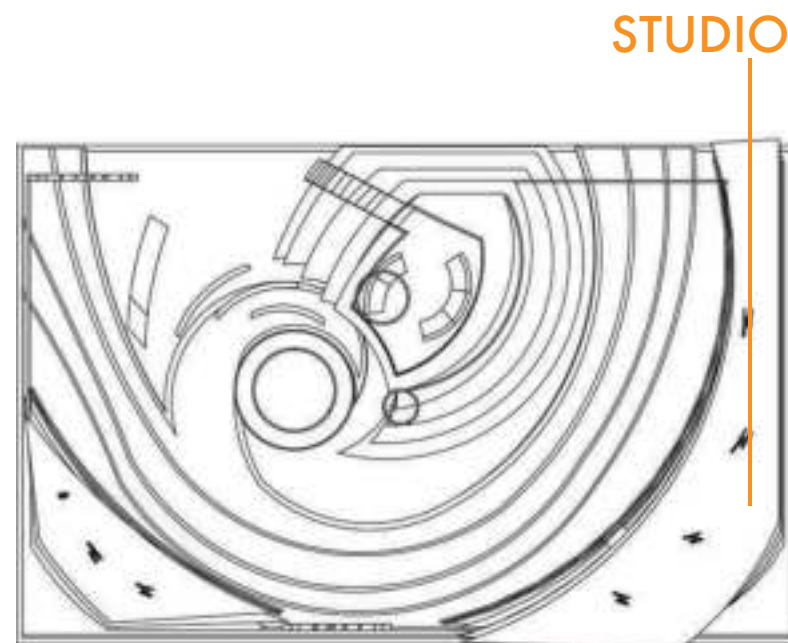

THE MULTIUSE STUDIO IN STRUCTURE 2 WILL BE AVAILABLE TO CIP GUESTS FOR YOGA, GAMES, AND EXERCISE CLASSES. IT WILL ENCOURAGE GUESTS TO EXERCISE IN A MORE FOCUSED SETTING. THE FLOOR OF THE STUDIO WILL BE MADE OF SENSACELL MODULAR SENSOR SURFACE THAT LIGHTS UP AS GUESTS MOVE ACROSS IT. THIS PRESSURE-SENSITIVE FLOORING WILL MAKE ACTIVITIES MORE FUN AND MAKE THE WORKOUT MEMORABLE. GUESTS WILL ASSOCIATE FUN EXERCISE WITH THE ATHLETA BRAND EXPERIENCE.

PHASE 4: GRAPHIC IDENTITY

PAGE 35	BASICS
PAGE 36	MURAL
PAGE 37	GRAPHICS
PAGE 39	INSTALLATIONS

FUTURA PT MEDIUM

ABCDEFGHIJKLM
NOPQRSTUVWXYZ
abcdefghijklmnop
qrstuvwxyz
1234567890

ATHLETA'S LOGO USES FUTURA PT MEDIUM TYPEFACE IN ALL CAPS. WE INCORPORATED THIS FONT INTO SIGNAGE AND GRAPHICS TO KEEP CONTINUITY WITH THE BRAND LOGO THAT IS IDENTIFIABLE TO CUSTOMERS.

WE USED AN ACHROMATIC COLOR PALETTE WITH POPS OF "COSMIC ORANGE" TO HIGHLIGHT IMPORTANT FEATURES. THIS ORANGE WAS ADVERTISED BY ATHLETA, AND IT COMMUNICATES THE HIGH ENERGY THAT WE WANT THE EXHIBITION TO HAVE.

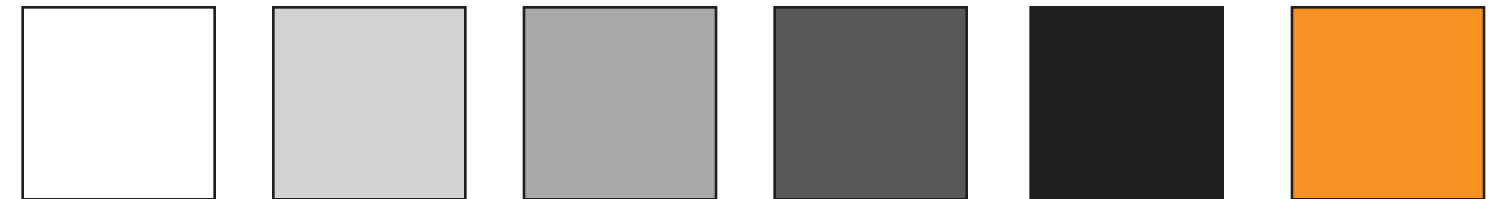

MURAL



THE MURAL WILL SPAN ACROSS THE INSIDE WALLS OF STRUCTURES 1 AND 2. IT WILL SHOW PROMINENT ATHLETES OF VARIOUS SPORTS CHRONOLOGICALLY FROM RIGHT TO LEFT. PHOTOGRAPHS OF FEMALE ATHLETES ARE OVERLAYED WITH ORANGE. GUESTS WILL SEE AN INCREASE IN ORANGE SQUARES AS THEY MEANDER THROUGH THE EXHIBIT, EVENTUALLY TRANSFORMING INTO SOLID ORANGE. THE MURAL IS MEANT TO ILLUSTRATE ATHLETA'S PURPOSE OF FEMALE ATHLETIC EMPOWERMENT.

MURAL

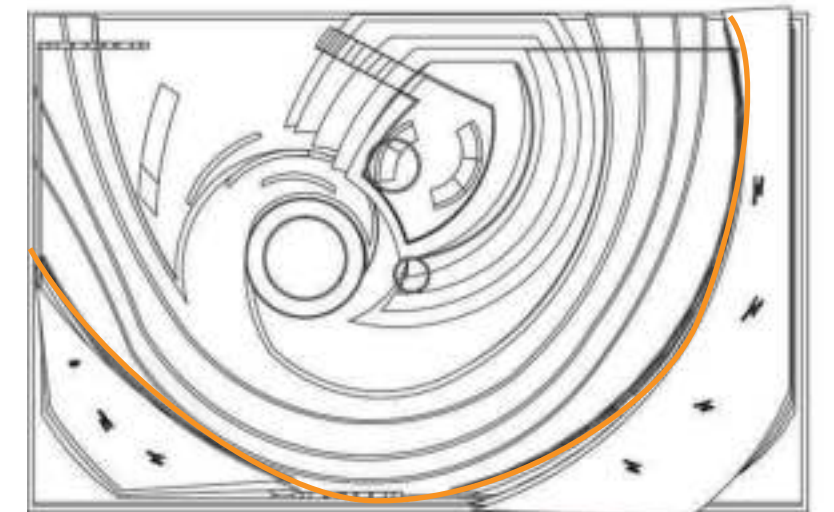



HANDOUTS AND SIGNAGE WILL EXEMPLIFY A SIMILAR FEMALE ATHLETIC EMPOWERMENT THROUGH WORD AND IMAGE. THE IMAGE ON THE LEFT ABSTRACTS THE GRADIENT EFFECT OF THE STRUCTURES IN THE EXHIBITION. THE IMAGE ABOVE SHOWCASES ATHLETA'S REFLECTOR JACKET AND SHOWS A DETERMINED FEMALE ATHLETE IN A MOUNTAINOUS WINTER LANDSCAPE.

GRAPHICS



THE GRAPHICS FOLLOW THE EXHIBITION COLOR SCHEME AND EXPRESS A LINK BETWEEN ATHLETICISM AND FASHION. ACTIVE WOMEN ARE SHOWN DOING A VARIETY OF EXERCISES TO APPEAL TO A BROAD AUDIENCE.

INSTALLATIONS

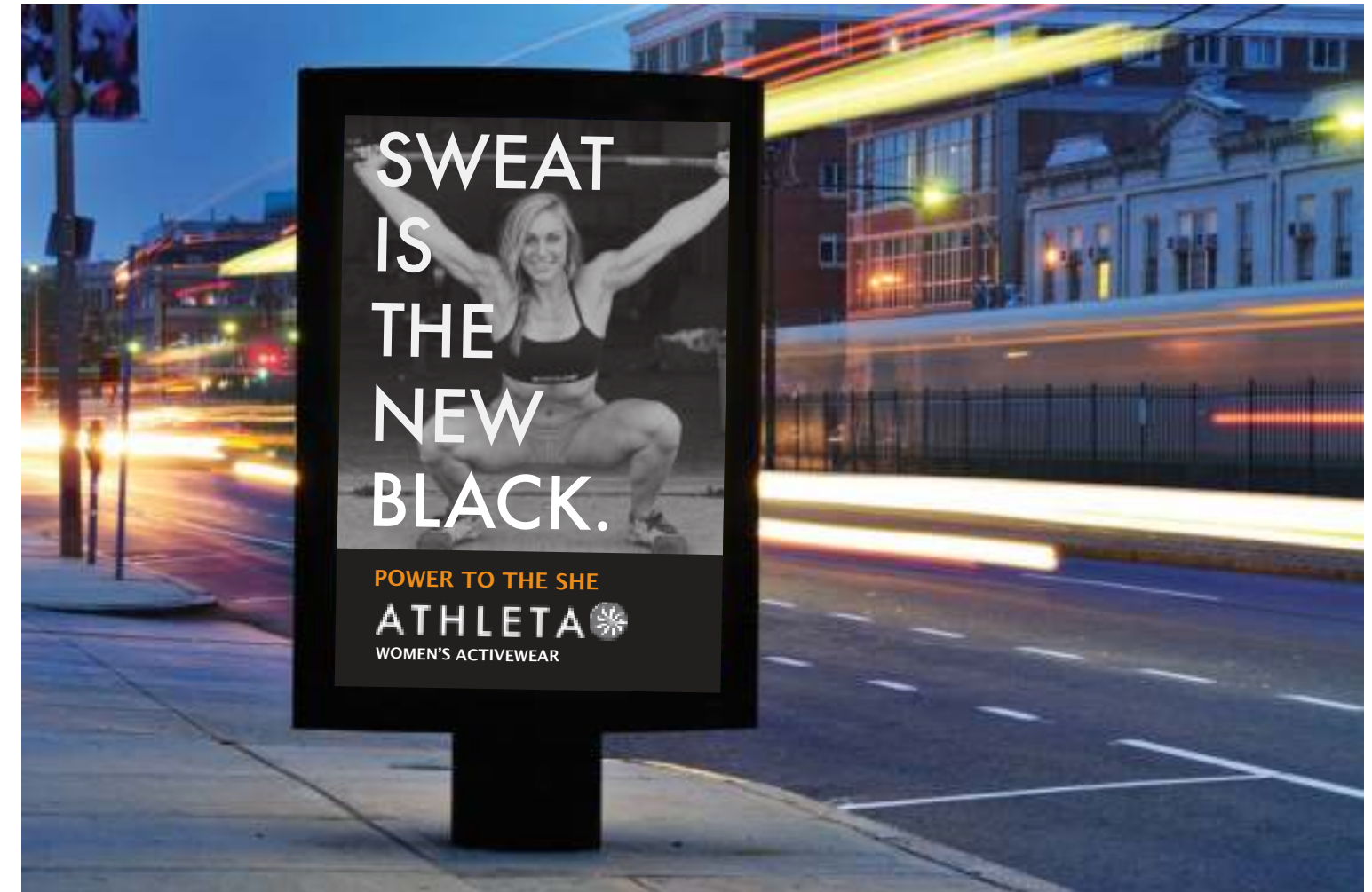

THE GRAPHICS WILL BE INSTALLED AS STREET SIGNAGE AND BILLBOARDS AROUND THE CITY TO ADVERTISE THE EXHIBITION. PRINTED VERSIONS WILL BE HANDOUT OUT TO PEDESTRIANS.

POWER TO THE SHE
